

SUITABLE FOR MODEL**PLEASE READ CAREFULLY AND FOLLOW ALL INSTRUCTIONS FOR YOUR OWN SAFETY**

IMPORTANT - An unswitched AC power source is required (120 to 277 volts, 50/60 Hz)

IMPORTANT - To reduce the risk of electrical shock, remove the normal AC power source(s) to the luminaire and disconnect the battery before servicing.

IMPORTANT- The emergency driver must be fed from the same branch circuit as the AC driver.

ATTENTIONS:

1. Installation should be performed by qualified personnel only.
2. Install in accordance with the National Electric Code and applicable local codes.
3. Do not use this emergency driver with accessory equipment other than recommended by manufacturer.
4. Do not use this equipment for other than intended use.
5. Equipment is suitable for use in dry and damp location where ambient temperature is -4°F to 104°F.
6. Equipment should be mounted in locations and at heights where it will not readily be subjected to tampering by unauthorized personnel.
7. Servicing of this equipment should be performed by qualified personnel only.
8. The is a sealed unit. Components are not replaceable. Replace entire unit when necessary.
9. Battery is rechargeable LiFePO4 type and must be recycled or disposed of properly.
10. Use Caution when servicing batteries. Battery acid can cause burns to skin and eyes. If acid is spilled on skin or eyes, flush acid with fresh water and contact a physician immediately.

RISK OF ELECTRICAL SHOCK

Disconnect normal power supply and emergency battery before servicing.

Make all electrical and grounded connections in accordance with the National Electrical Code and any applicable local code requirements.

All wiring connections should be capped with UL approved wire connectors.

RISK OF INJURY

Wear gloves and safety glasses at all times when removing luminaire from carton, installing, servicing or performing maintenance.

Avoid direct eye exposure to the light source while it is on.

Account for small parts and destroy packing material, as there may be hazardous to children.

RISK OF FIRE

Do not mount near gas or electric heaters.

Keep combustible and other materials that can burn away from luminaire and power supply cords.

Use minimum 194°F supply conductors

WIRE CONNECTION

Universal voltage driver permits operation at 120V thru 277V, 50 or 60 Hz. 0-10V control wires must be rated for 300V minimum.

1. If switching, connect SWITCHED black lead to a switch.
2. If not using a switching method, connect the UNSWITCHED and SWITCHED black lead together.
3. Connect the UNSWITCHED black fixture lead to the LINE supply lead.
4. Connect the COMMON white fixture lead to the COMMON supply lead.
5. Connect the GROUND wire from fixture to supply ground.
6. If 0/1-10V dimming is used, connect the purple lead from fixture to the (V+) DIM lead.
7. If 0/1-10V dimming is used, connect the gray lead from the fixture to the (V-) DIM lead.
8. Connect the battery to emergency driver.

CAUTION:

1. All unused leads must be capped and insulated.
2. Do NOT connect the battery until AC power is supplied to the emergency driver.
3. A short-term discharge test may be conducted after the emergency ballast has been charging for one hour. Charge for 24 hours before conducting a long-term discharge test.

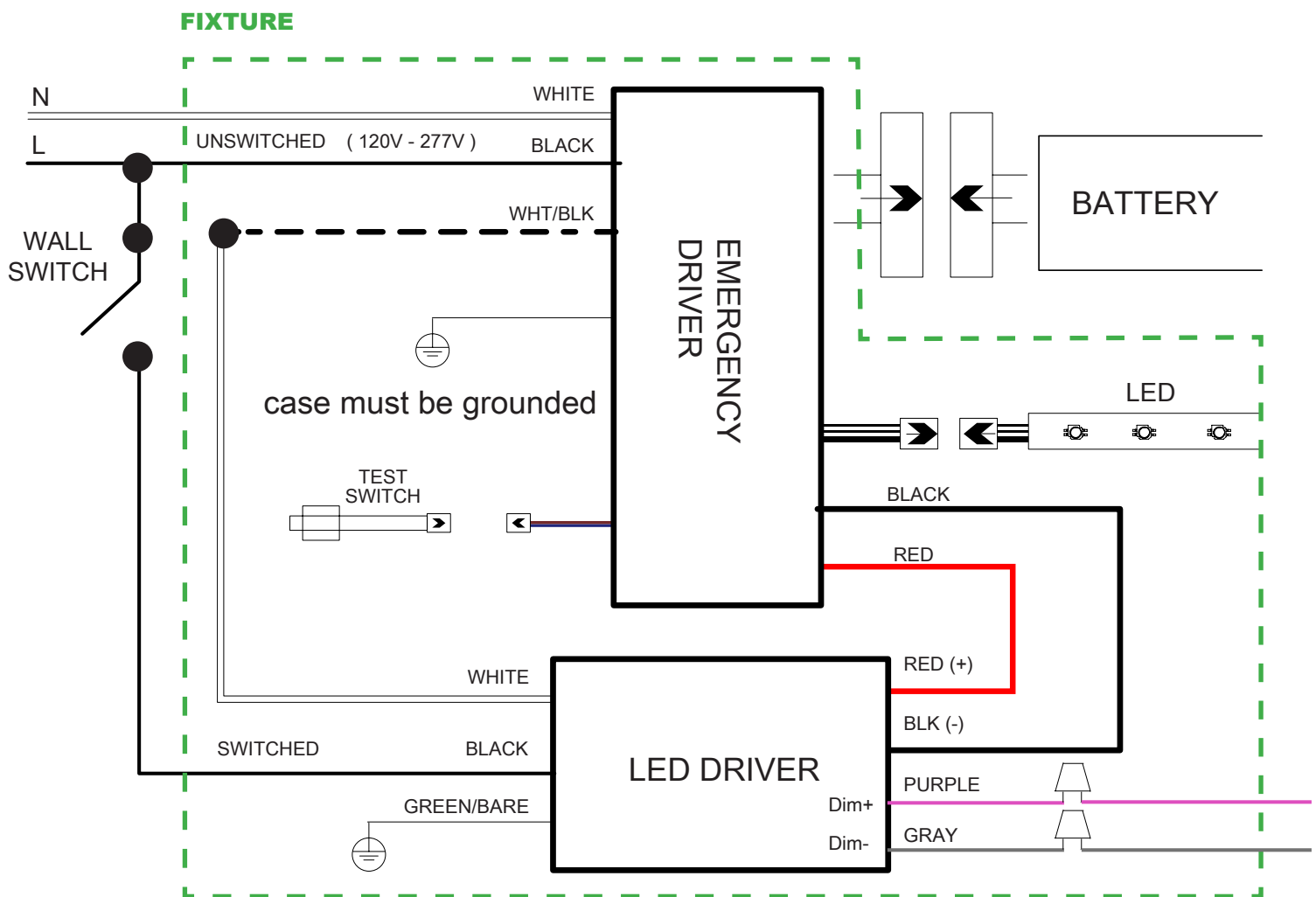

INSTALLATION

ATTENTIONS:

The emergency test button is pre-installed on fixture. DO NOT remove the pre-installed emergency test button without factory permission. If need a remote test switch please contact factory.

ACCESSORY PACK



WIRE NUT X 5

INSTALLATION STEPS

Notes:

1. DO NOT connect the battery until AC power is supplied to the emergency driver.
2. DO NOT attempt to remove the lens from the metal lens frame.
3. Make sure the safety ropes always are connected between luminaire base and lens frame assembly.

Step 1.

Locate the mounting points based on the Dimension Drawing. See Figure 1.

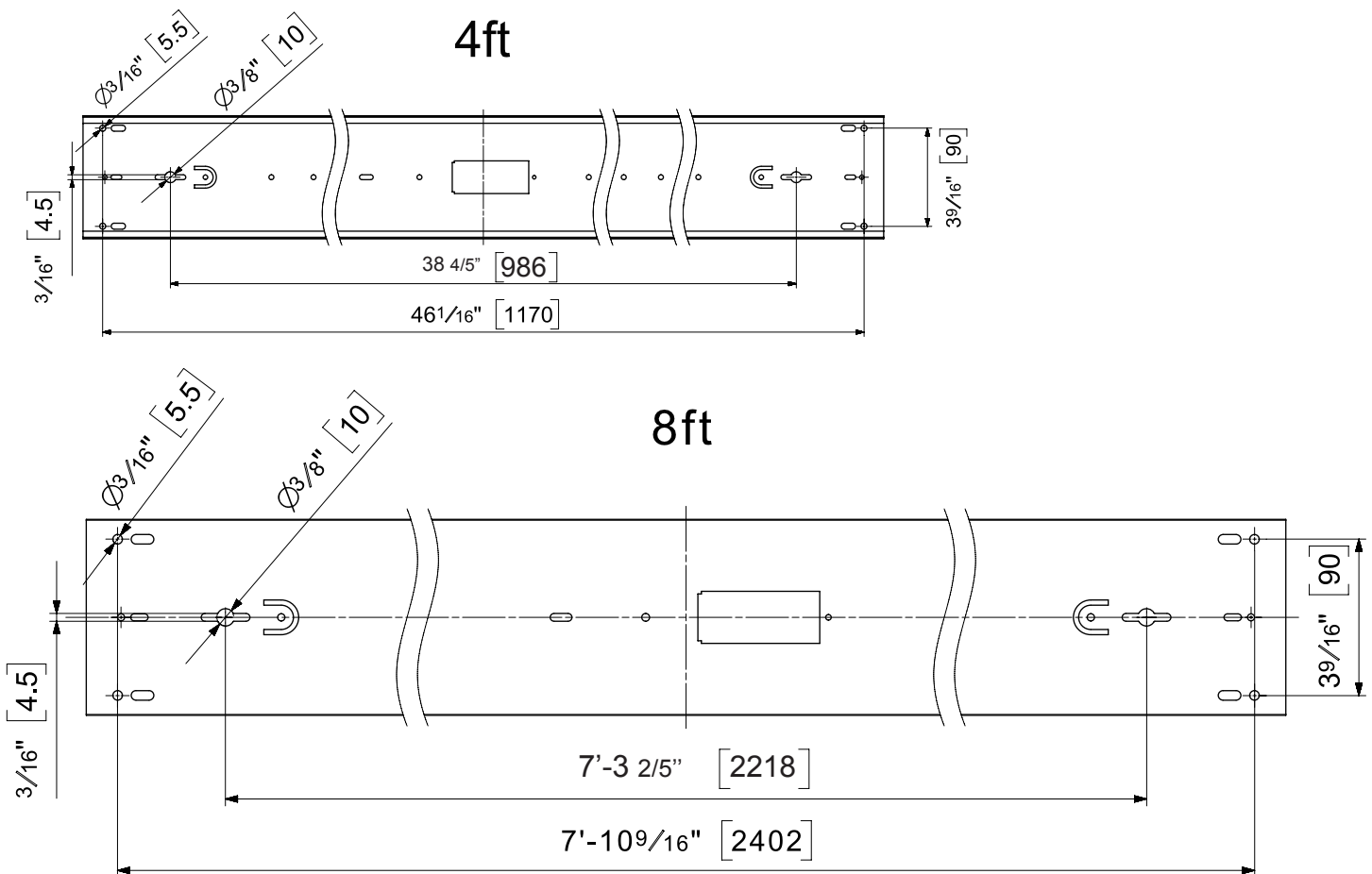

Figure 1

Step 2.

Remove the Lens Frame Assembly from the Luminaire Base by removing the four screws on the side of the base. See Figure 2.

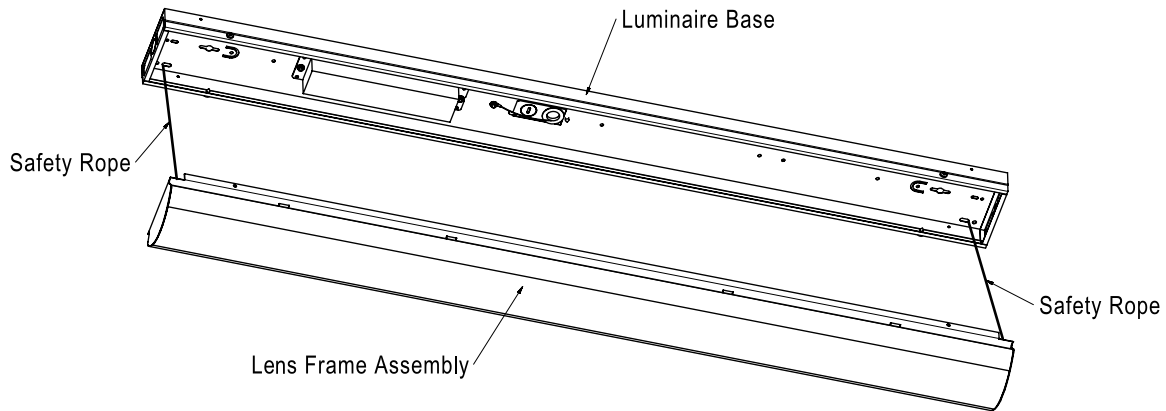

Figure 2

Step 3.

Bring customer supplied wires into luminaire through the Wiring Knockouts on the backside or end cap. See Figure 3.

Step 4.

Choose the proper installation method and prepare suitable installation tools and accessories.

SURFACE MOUNT

Depending on structural conditions, secure luminaire to mounting surface by customer supplied anchor screws, toggle bolts or suitable fasteners into Keyhole Slots. See Figure 3.

CHAIN MOUNT

Attach customer supplied V-hooks to each end of the luminaire base. See Figure 3.

Attach customer supplied Chain to the V-hooks and mount surface. Make sure the luminaire is balanced.

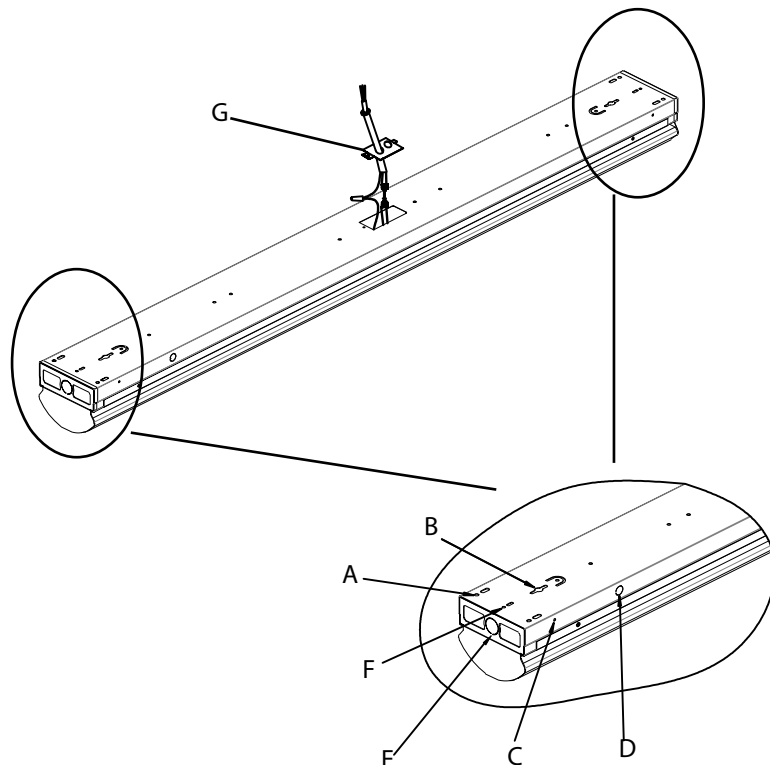

- A. V-hook Openings for Chain Mounting
- B. Keyhole Slots for Surface Mounting
- C. Wire Guard Openings
- D. Knockouts for Emergency Charging Indicator
- E. Wiring Knockouts
- F. Safety Chain Openings
- G. Wiring Cover with knockout

Figure 3

Step 5

Connect wires as shown in wiring diagram with wire nuts.

Step 6

Connect the battery with the emergency driver by plug.

Step 7

Reattach Lens Frame Assembly to luminaire base by locking the removed four screws.

OPERATION

1. When A.C. power is applied. The LED Emergency Equipment is in the standby charging mode. The Charging Indicator is illuminated, indicating that the battery is being charged.
2. When power fails, the emergency ballast automatically switches to emergency power (internal battery) operating at reduced illumination. The emergency ballast supplies 5W of power in emergency mode for a minimum of 90 minutes.
3. When the AC power is restored, the LED Emergency ballast automatically returns to charging mode.

TESTING AND MAINTENANCE

Although no routine maintenance is required to keep the emergency driver functional, it should be checked periodically to ensure that it is working. The following schedule is recommended:

1. Monthly - Visually inspect the charging indicator light. It should be illuminated. Test the emergency operation of the fixture for a minimum of 30 seconds. When the test switch is depressed, the LED array should operate.
2. Annually - Conduct a 90-minute discharge test. The LED array should operate for at least 90 minutes.

If the luminaire fails any of these checks, consult service personnel.